

PT-25C HAND TORCH

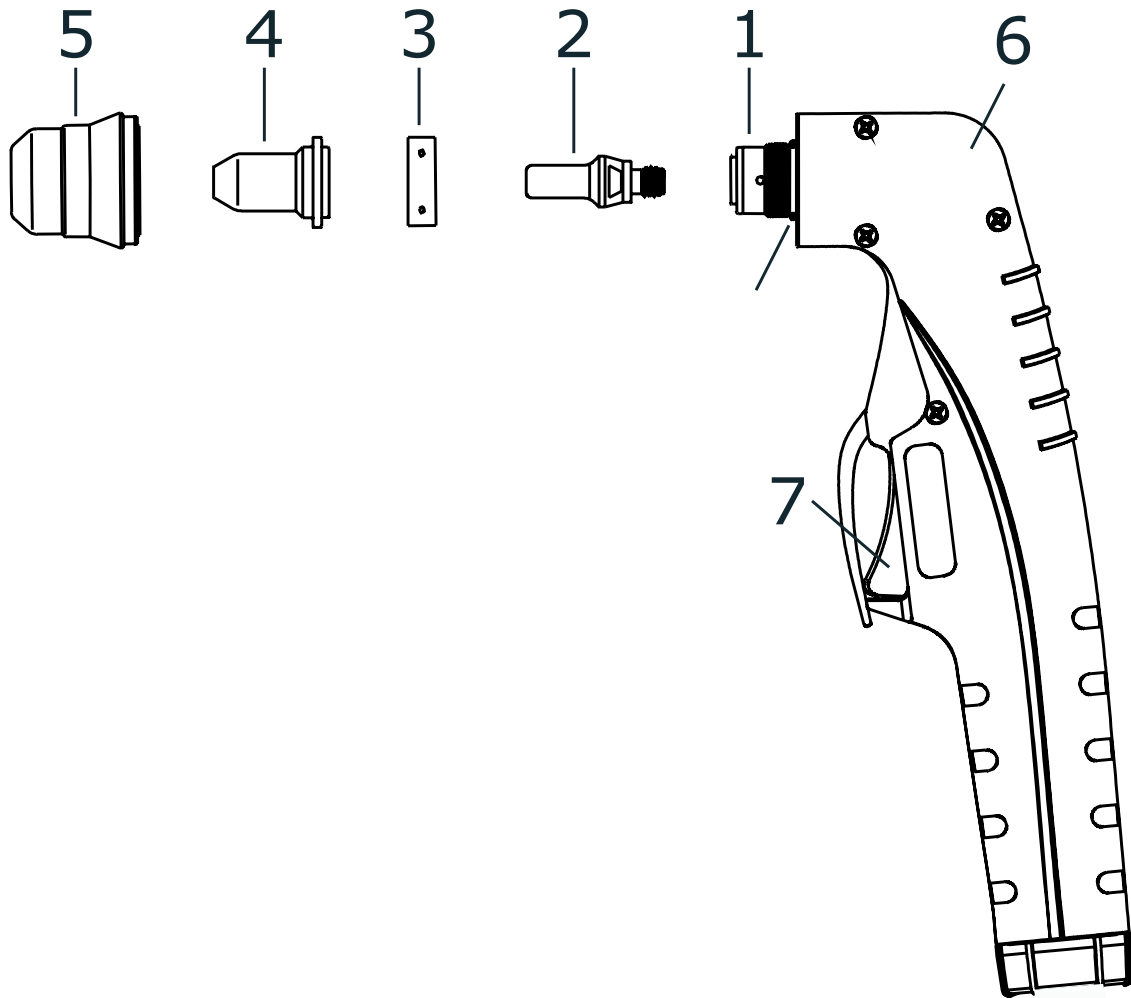

Torch Model	
Description	Part Number
Trafmet S25 Plasma Torch	4 Mt 09627

Spare Parts	
Description	Part Number
1	09627 Hand Torch
1a	09601 Torch head
1b	51620.60 O-Ring
2	52582 Electrode Hf -back arc striking
3	60028 Air diffuser
4	51318.06 Tip 0,65 (10-20A) back arc striking
	51318.08 Tip 0,8 (20-30A) back arc striking
	51318.09 Tip 0,9 (40A) back arc striking
5	60389K Outside nozzel, 2 holes
6	09605-Black Handle complete
7	07301.20 Trigger
8	51866 Circle cutting attachment

Technical Data			
Max Current	25A	Gas Pressure	3.0 Bar
Duty Cycle	60%	Gas Flow	50l/min
Gas	Air/N	with Pilot Arc	